



COMPOMAC

via Bruno Buozzi, 6 - 40057 CADRIANO - Granarolo E.
(Bologna) Italy - tel. 051/765651 - fax 051/763120
E-Mail: info@compomac.it - Internet <http://www.compomac.it>

S.p.A.

COMPOGEAR



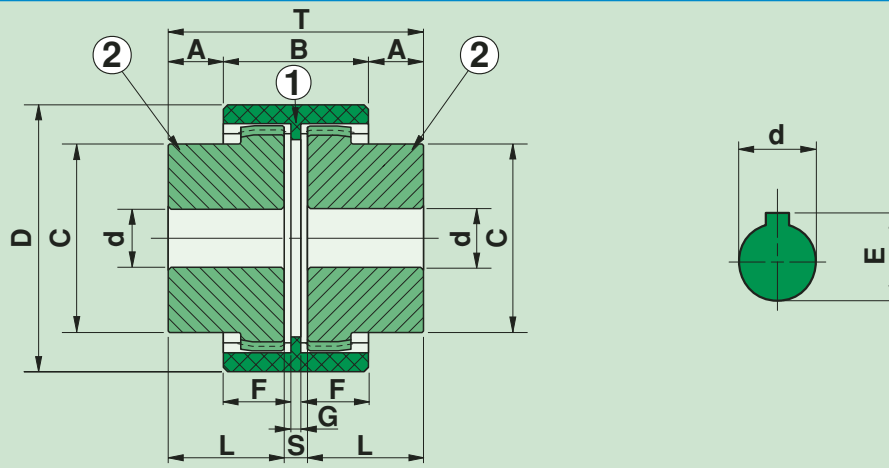

COMPOGEAR è una serie di giunti composti da due mozzi a dentatura bombata, in acciaio (2) che ingranano su una slitta in poliammide (1) dentata internamente. Il particolare disegno bombato della dentatura dei mozzi e la combinazione acciaio-poliammide permette di lavorare senza usura e quindi senza lubrificazione e manutenzione anche in presenza di importanti disallineamenti assiali, angolari, radiali degli alberi da collegare. COMPOGEAR è resistente a tutti i lubrificanti e fluidi idraulici e può essere impiegato in una gamma di temperature da -25°C a +80°C.

COMPOGEAR is a series of coupling consisting of two steel, crowned teeth hubs (2), which are connected with a polyamide internally toothed sleeve (1). The special new design of the crowned teeth hubs and the lubrication free combination of steel with polyamide ensure good sliding properties and leads to low maintenance and low wear operation, also with important axial, angular and radial misalignment of the shafts. COMPOGEAR is resistant to all types of lubricants and hydraulic fluids and can be used at a temperature range of -25°C ÷ +80°C.

grandezza size	dimensioni overall dimensions											velocità massima max speed rpm	coppia nominale nominal torque Nm	coppia max max torque Nm	disallineamento misalignment			inerzia inertia J Kg cm ²	massa mass Kg	
	DIN 6885/1		E	A	B	C	D	F	G	L	S				T	ax ± mm	rad mm			ang [°]
41 - 14	6	14	16.3	6.5	37	25	41	16	5	20	10	50	14.000	10	20	± 1	± 0.3	± 1°	0.23	0.16
48 - 19	10	19	21.8	7.5	37	32	48	16	5	21	10	52	11.800	16	32		± 0.3		0.42	0.24
53 - 24	10	24	27.3	7	40	36	53	15.5	9	21	12	54	10.600	20	40		± 0.4	su ogni mozzo on each hub	0.84	0.33
66 - 28	8	28	31.3	18	46	44	66	18.5	9	35	12	82	8.500	45	90		± 0.4		2.8	0.86
76 - 32	12	32	35.3	17	48	50	76	19.5	9	35	12	82	7.500	60	120		± 0.4		4.9	1.10
82 - 38	12	38	41.3	17	48	58	82	19.5	9	35	12	82	6.700	80	160		± 0.4		7.8	1.40
91 - 42	12	42	45.3	19	50	68	91	20.5	9	38	12	88	6.000	100	200		± 0.4		12.9	1.96
98 - 48	12	48	51.8	26	50	68	98	22	6	45	12	102	5.600	140	280		± 0.4		16.5	2.38

Per una corretta selezione del giunto COMPOGEAR, le coppie nominali devono essere declassate del fattore di servizio f_s . Inoltre la coppia di spunto non può superare la coppia massima del giunto. Coppie uniformi e alberi ben allineati consentono l'utilizzo del giunto fino alla coppia massima. Disallineamenti massimi e velocità massime non possono coesistere contemporaneamente e così la presenza di un disallineamento riduce le velocità massime, secondo la tabella.

For a correct selection of the COMPOGEAR coupling, the nominal torque must be derated by the f_s service factor. The maximum starting torque must not exceed the maximum torque of the coupling. With constant torque and well aligned shafts, COMPOGEAR can be used up to the maximum torque. The maximum misalignment and the maximum speed cannot co-exist at the same time; therefore the presence of misalignment reduces the possibility of maximum speed, as indicated in the table.

